

CAPACITY	SYMBOL/ SERIAL NO.	CIRCUIT DIAGRAM
AC 230V, 60Hz		
36W x 2		

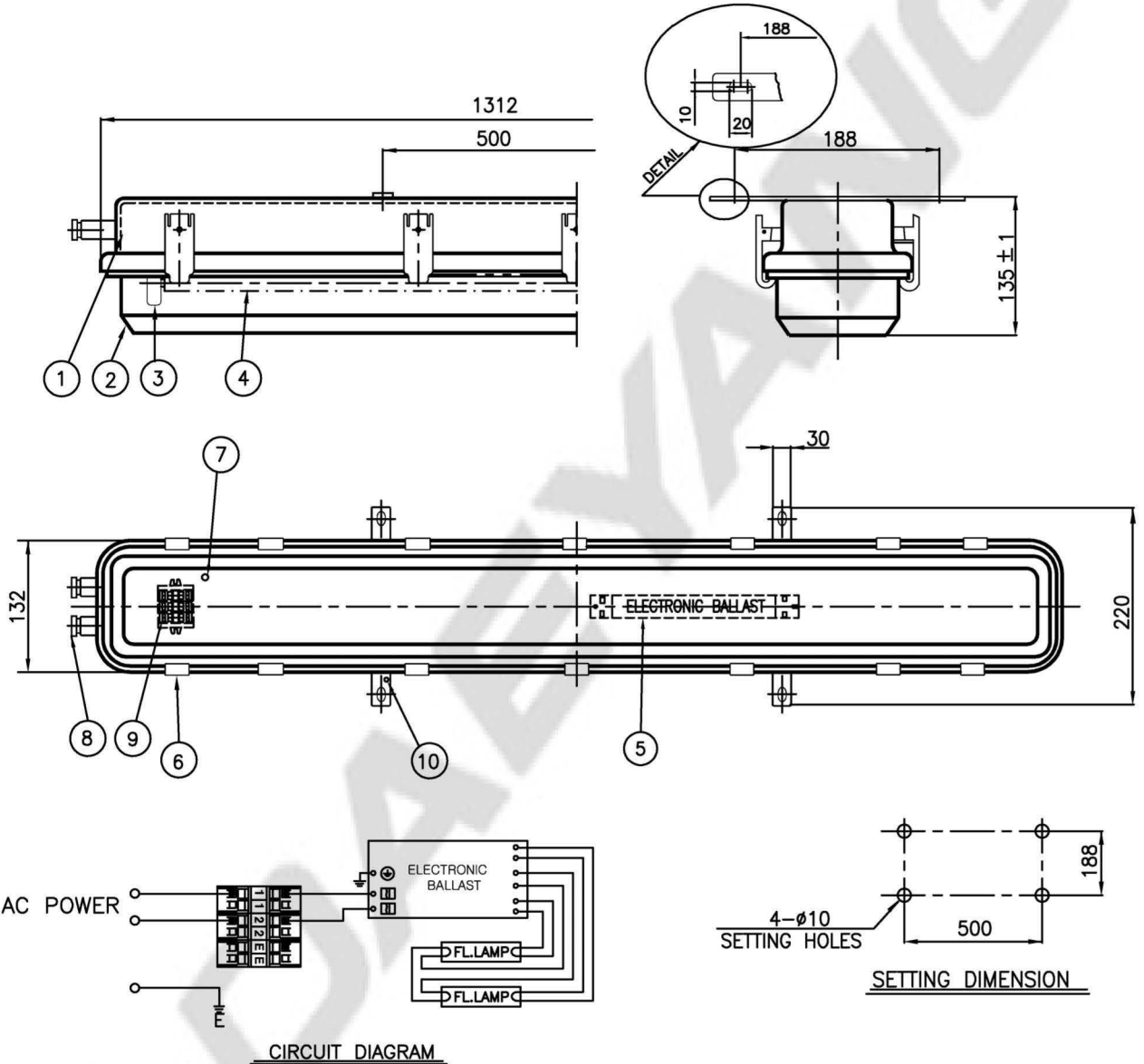

10	OUTSIDE EARTH BOLT	STAINLESS STEEL304	1	M5	5	ELECTRONIC BALLAST	-	1	
9	TERMINAL BLOCK	NYLON	1	CLAMPING 3P	4	LAMP(3-BAND)	-	2	
8	CABLE GLAND	BRASS	2	φ14~φ17.5	3	LAMP HOLDER	POLYCARBONATE	4	
7	INSIDE EARTH BOLT	STAINLESS STEEL304	1	M4	2	GLOBE	POLYCARBONATE	1	
6	LATCH	STAINLESS STEEL316L	14		1	BODY	STAINLESS STEEL316L	1	
NO	NAME OF PARTS	MATERIAL	Q'TY	REMARKS	NO	NAME OF PARTS	MATERIAL	Q'TY	REMARKS

APPROVED	B. K. KIM	UNIT	MM	TITLE; FLUORESCENT CEILING LIGHT (SURFACE TYPE) FOR MARINE USE			
CHECKED		SCALE	N/S				
DRAWING	B. I. KIM	COLOR	N-9.3				
DATE	2015.12.04	IP	66/67				
				MODEL NO.	FL240WS-0236EIUWNM2Ww17h12C840	WEIGHT	6.6 Kg
				DWG NO.	L11480951	SHEET NO.	48